

Received November 9, 1769.

X. *An Account of some Improvements made in a new Wheel Barometer, invented by Keane Fitz Gerald, Esquire, F. R. S. In a Letter to Charles Morton, M. D. Sec. R. S.*

DEAR SIR,

Read Feb. 22, 1770. I GAVE a former description and drawing of a wheel-barometer of a new construction, with registers to mark the rise and fall of the mercury, which were published in the first part of the fifty-second volume of the Philosophical Transactions for the year 1761. As that instrument has continued to operate effectually by the weight of a few grains only, and the registers to mark the limits of the ascent and descent of the mercury in the tube very exactly ever since, it has induced me to attempt a further improvement, which I have also found to answer effectually; and take the liberty of desiring the favour of you to lay a description and drawing of it before the gentlemen of the Royal Society, if you think a communication of the kind worth their notice.

As

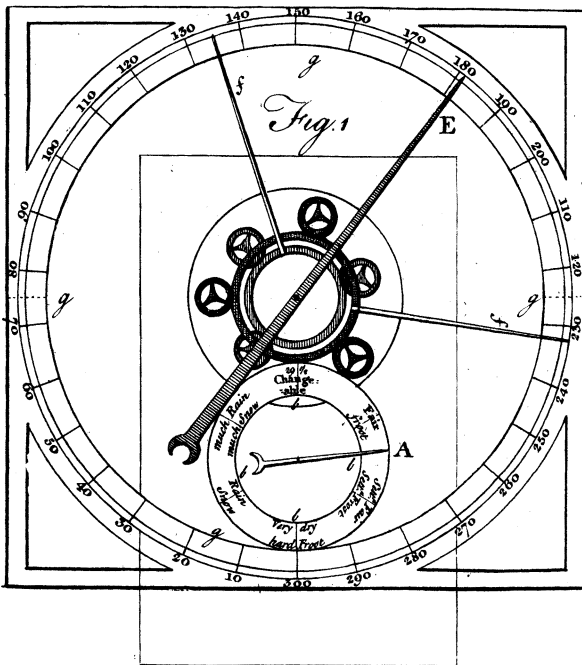
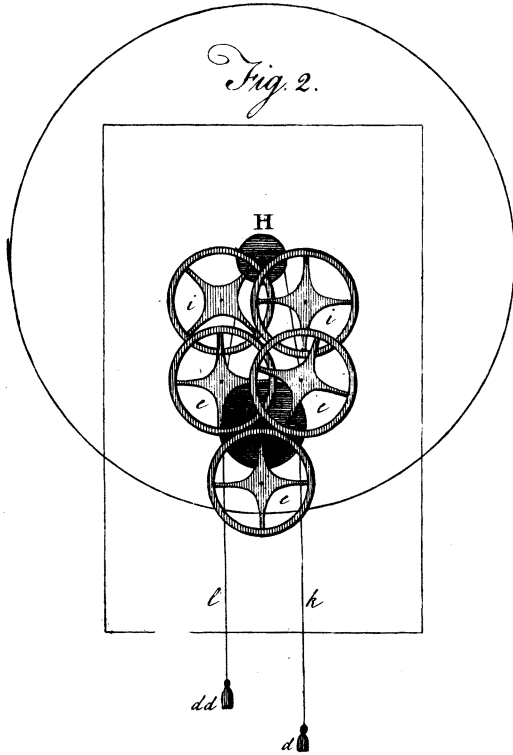

As the improved instrument is like that already described, except in the dial-plate, and part of the wheel work, I have made a drawing of the parts, only, wherein they differ.

The smaller index A. (TAB. IV.) fig. 1. which moves in the circle *b, b, b, b*, about 4 inches diameter, is fixed on the axis of a double pulley B. fig. 2. nearly 1 inch diameter, which makes one revolution by a rise, or fall of 3 inches of the mercury in the tube.

The pivots of the axis of the pulley B, are placed, each within 3 friction wheels, *e, e, e*, fig. 2. 2 inches diameter.

The larger index E. fig. 1. which moves in the circle *g, g, g, g*, — 10 inches diameter is placed on the axis of the double pulley H, about $\frac{1}{3}$ inch diameter, to make 3 revolutions exactly, for 1 revolution of the pulley B. Each of the pivots of the axis of this pulley is placed on 2 friction wheels *ii*, fig. 2.

The circle *b, b, b, b*, fig. 1. is divided into 3 equal parts; one for each inch the mercury rises or falls in the tube, and is marked 28, to 31 inches, with rain, changeable, fair, &c. inscribed, as other barometers generally are. Each of these parts is subdivided into 10.

The larger circle *g, g, g, g*, is divided into 300 equal parts, and marked 10, 20, &c.

The ivory cone, *d*, which rests on the mercury in the tube, is suspended by a silk thread *k*, fig. 2, which surrounds the outward pulley, B, and passes also 4, or 5 times round the outward pulley H, to which the end is fastened.

The thread, *l*, by which the counterbalance, *dd*, is suspended, surrounds in like manner the inward pulleys B, and H, but in a contrary direction. The weight *d* is about 8 grains heavier than the counterbalance, *dd*, which is fully sufficient to move both the indexes, and also the registers; and is so slight a weight, as does not at all impede the rising of the mercury in the tube.

As the cone *d* is supported by the mercury; when it rises or falls in the tube, the pulleys B and H are moved round accordingly; and as a rise or fall of 3 inches causes one revolution of the pulley B, and 3 revolutions of the pulley H, the indexes A, and E, placed on the axes of these pulleys, must be carried round the circles *b, b, b, b*, and *g, g, g, g*, in like manner.

The index A is moved $\frac{1}{3}$ of the circle *b, b, b, b*, by 1 inch rise, or fall of the mercury, and the index E the whole circle *g g g g*; which, being about 30 inches in circumference, and divided into 300 equal parts, shews half a division very perceptibly; so that the index E marks distinctly the 600th part of an inch rise or fall of the mercury. And by placing the registers *f, f*, fig. 1. close to the index, it must carry one along with it, when it moves; leaving it on its return, to mark the limits of its motion.

It requires a good deal of nicety and exactness in making and placing the friction wheels and pulleys; which require to be very light, and the pivots fine and small. The machinery of this, as also of the former, was made by Mr. Vulliamy, watchmaker to her Majesty; which is so well adjusted, that it
has

has not been in the least out of order, in nine months I have had it ; nor the other in nine years.

The exactness and facility with which an account of the variations in the weight of the atmosphere may be kept, with the help of a barometer of this kind, must be very evident. I have frequently found, by extraordinary variations that have happened in the night, when the wind has risen considerably, how little the observations made with common barometers are to be depended on ; and have several times found by the registers, that the mercury had sunk 50 or 60 divisions ; and one night particularly had sunk 117 degrees, and returned within a degree and half of the place I had marked it on going to bed. When a strong gust of wind rises, one may very plainly perceive the index of this latter barometer to sink several divisions, and rise again as it abates.

Besides the satisfaction that a barometer of this kind might afford to a curious observer, I should imagine it might also be usefully applied to the finding the height of the atmosphere ; with a much greater degree of exactness, at least, than can well be afforded by any other.

It is generally allowed from experiments, that a column of air 72 feet high is equal in weight to 1 inch of water of the same base ; so that, if the air were of equal density throughout, the atmosphere could be little more than 5 miles high. But as the density is found to decrease by the difference of pressure, and the air to be more rarified or expanded in proportion to its distance from the earth, it seems reasonable to conclude, that if, by accurate experiments,

ments, the ratio of its decrease were found regular in proportion to the distance from the earth, its height might be estimated with a much greater degree of precision than it has been hitherto; though it seems generally allowed that its real height cannot possibly be ascertained.

The impossibility of observing the difference of the pressure of the atmosphere at small distances with accuracy by a common barometer, the scale of which is but 3 inches, is very evident; how far this instrument, the scale of which is 90 inches, might be conducive to the purpose, is submitted to the judgment of others.

I should imagine it would not be difficult, with a proper teakle, to raise a barometer of this kind gently, as high as 200 feet; and if it were raised from the ground, and let down again from each distance of 20 feet, the registers would mark very exactly to the 600 part of an inch at what height the mercury stood at each distance; so that the weight of each column of air of 20 feet, to the height it could be raised, would be found pretty exactly. And if a proper apparatus were fixed for raising the barometer, the experiments might be repeated, as often as requisite, with very little trouble.

Experiments of this nature cannot well be made by a single person; but if an instrument of the kind should be deemed useful for the purpose, I should very willingly lend it, and also any assistance I could give, in making the experiments.

I shall with great pleasure shew you the instrument whenever you favour me with your company;
or

[79]

or to any of the gentlemen of the society, who may think it worth examining.

I am, S I R,

Your most obedient servant,

Poland Street,
Nov. 8, 1769.

Keane Fitz Gerald.

Descrip-